

4WS - 2"

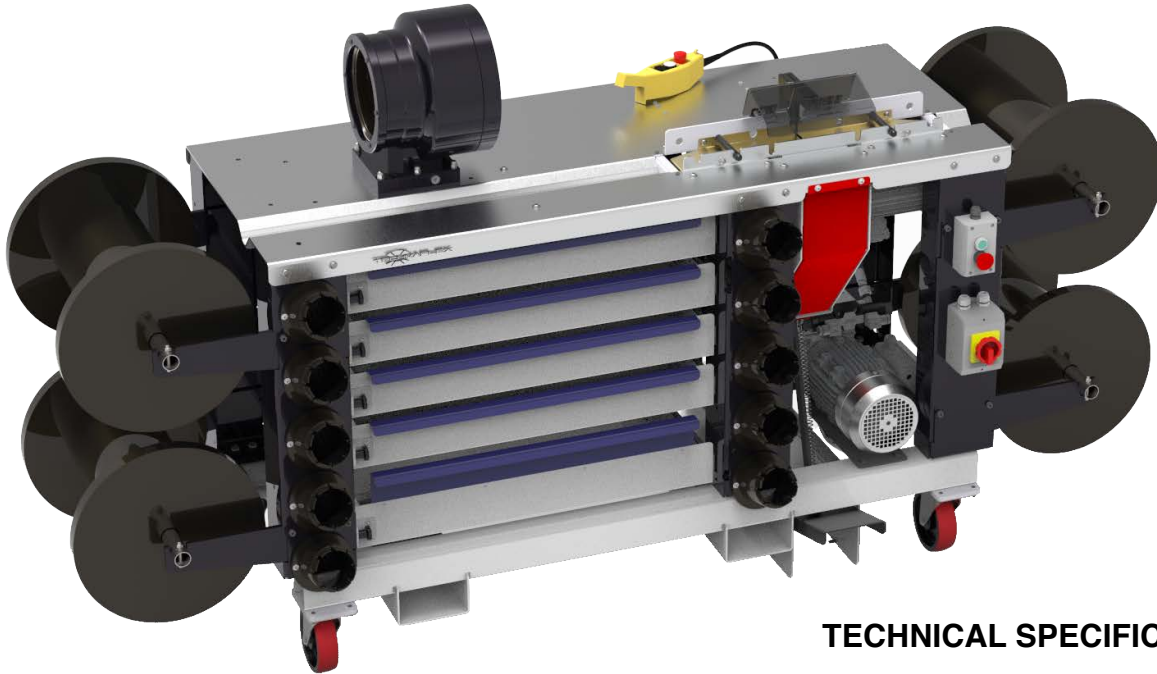

Outfitted with the V CRIMP 240 L crimping machine, this version of the "Hose Room on Wheels" has the extra power needed to cut and crimp WS hoses up to 2". This version of the "Hose Room on Wheels" also comes with an expanded range of dies to suit the greater capacity and a remote controller for the crimping machine for those bulky, difficult to handle jobs.

TECHNICAL SPECIFICATIONS

VOLTAGES	NET WEIGHT
208/240V-3PH-60HZ 220/240V-1PH-50HZ 220/240V-1PH-60HZ 220/240V-3PH-50HZ 380/415V-3PH+N-50HZ	950kg
CRIMP FORCE	DIMENSIONS
240 t	2,487 x 810 x 1,370mm (98 x 32 x 54")
CRIMP RANGE	MOTOR
4-76mm (0.157 - 2,992")	5 - 7 - 8 KVA
CAPACITY	STANDARD DIES
4ws: 2" max	15,18, 21, 24, 27, 30, 33, 36, 39, 42, 45, 48, 51, 57, 62, 66, 70

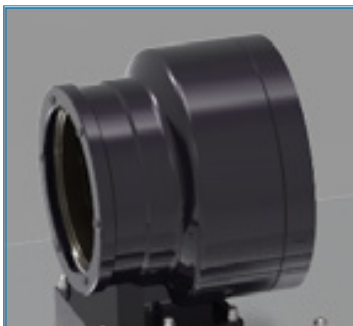

Robustly designed, with a high crimping speed and up to 240 tonnes of crimping force, the V CRIMP 240 L is just what you need to handle both the bigger and smaller assembly jobs efficiently. The built-in micrometer and radial die movement ensure accuracy and repeatability for WB & WS hoses up to 2".

ADDITIONAL FEATURES:



The tough, ball-bearing slide drawers with internal dividers are ideal for keeping a comprehensive selection of fittings, ferrules and essential tools close at hand.

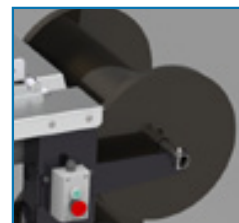

Designed to allow quick loading and unloading of up to 4 different hoses, the hose spool storage also facilitates hose handling and management during use.



The robust, lockable castors ensure easy, convenient movement of the "Hose Room on Wheels" whilst also ensuring stability during use. The built-in fork-lift channels also make it easy to safely lift the unit on and off vehicles for use in on-site maintenance activities.