

S PUSH 1500

EXPERT SERVICE LINE
BENCHTOP COUPLING INSERTER

KEY FEATURES

- Compact
- Sturdy
- Powerful

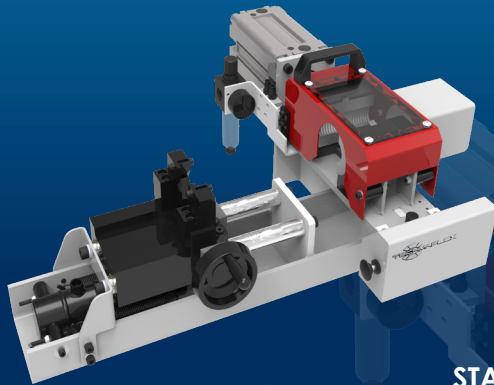

STANDARD



Hydro-pneumatic pump

TECHNICAL SPECIFICATIONS

CAPACITY

- 2wb: 2" max.
- 4ws: 2" max.
- 6ws: 2" max.

DIMENSIONS

750 x 660 x 300 mm
(30 x 26 x 12")

NET WEIGHT

70 kg (154 lb)

POWER SUPPLY

Compressed air (7 bar)

TECHNICAL FEATURES

Optional tool: for small bore 3/4", 3/8", 1/2" shell